

HUISDRILL 12000

NEXT GEN DEEPWATER DRILLSHIP

HUISMAN PRODUCT BROCHURE



DRILLING

GENERAL INTRODUCTION

Huisman offers complete drilling packages and is dedicated to explore and realise new solutions to improve drilling efficiencies and reduce well costs. Our projects are typically complex and innovative, requiring solution-aimed thinking, technical excellence and partnerships with our clients. This approach has resulted in a number of new value-adding solutions and delivery of innovative and technically challenging drilling equipment sets.

Huisman has in-house capabilities for vessel design. This allows us to provide solutions in which vessel and equipment are fully integrated, leading to radically improved designs for drilling vessels. The first drillships based on these concepts have proven to represent a major step change in our industry.

The unique combination of our in-house design and engineering expertise, production facilities, testing capacity, and installation locations, enables us to deliver custom-made, state-of-the-art equipment on a turnkey basis: in time, with fully operational equipment from day one. All Huisman products are designed and built in accordance with international standards and certified by recognised authorities such as ABS, API and DNV.

EXISTING

NOBLE BULLY AND NOBLE GLOBETROTTER



NOBLE BULLY I

NOBLE BULLY I AND II

In the first half of 2007 Huisman was awarded a contract to design and manufacture the drilling tower and related pipe, riser and BOP handling equipment for the Bully I. The order for outfitting a second vessel followed in 2008. The Bully drillships are designed to offer a lower cost and more flexible alternative for drilling in ultra-deep and arctic conditions. The selection of our in-house designed compact box type drilling tower instead of a conventional derrick allows a significantly smaller sized vessel compared to other deep-water drillships of similar capacity. Both ships are jointly owned by Shell and Noble Drilling.

NOBLE GLOBETROTTER I AND II, HUISDRILL 10000

After the Bully's were contracted Huisman concluded that the overall layout could be improved. The Globetrotter drill ship was designed with the integrated design approach: Since drilling is the 'mission' of the unit, the 'Mission Equipment', the drilling system, is first designed and then the vessel is designed around the 'Mission Equipment'. The result is a purposefully and efficiently designed 'system'. The Globetrotter is the same size

as the Bully but can carry 70% more payload and has much more functional deck space. The design of the drilling package focuses on drilling efficiency and versatility. The drilling package is suited to accommodate the latest drilling technologies. The Huisman Dual Multi Purpose Tower (DMPT) has no V-door limitation. The handling procedure of the SSBOP and X-mas trees is changed, resulting in a drastically reduced substructure height. The CoG is lowered, which increases the stability of the vessel. This results in a vessel which can carry 20,000mt payload (same as the competition) while she has a displacement of only 54,000mt (nearly half of the competition).

INSTALLATION AND COMMISSIONING

Since the DMPT is a single integrated unit that houses all equipment, the interface with the vessel is greatly simplified. In combination with the Huisman substructure that houses the complete drill floor, control cabin, drilling VFD's, and HPU, the DMPT can be fully tested and commissioned on our quayside. After the testing and commissioning phase the DMPT can be installed with one single lift onto the vessel, significantly

UNITS



NOBLE GLOBETROTTER I

reducing the time the vessel has to stay at the quayside. This integrated approach allows both Huisman and the shipyard to build the equipment and vessel simultaneously. It also reduces the number and complexity of the interfaces between the vessel and the equipment, which reduces the time for installation and commissioning.

OPERATIONS

The Bully I currently operates in the Gulf of Mexico, while the Bully II operates offshore Brazil. In a year both saved 5.5 days by eliminating cutting and slipping of the wire rope alone. The Bully I and II had less than 0.4% downtime on the Huisman equipment. The GT I currently operates in the Gulf of Mexico. The GT II operates offshore Benin, afterwards she will move to the Black Sea. Prior to crossing the Bosphorus the crown section of the drilling tower will be removed with the ships own pedestal crane. This can be done within a week. On the first well the GT I lowered a very heavy casing string of 2.1 million lbs without any problems. GT II drilled a well in 68 days (while the AFE was 98 days).

FLOATER RIG OF THE YEAR 2013 & 2014

Martin Vos – Shell’s VP deepwater wells: “The Noble Globetrotter and Noble Bully projects are very unique because they are game changer projects – from the late 1800’s to recently, drilling rigs have used traditional derricks and offshore ever bigger rigs were being built and with this project we have moved towards drilling rigs with multipurpose towers and a high level of efficiency and automation, as well as improved safety exposure for the crews. In addition the overall concepts enabled smaller rig footprints with better environmental performance as well as integrated improved pipe and riser handling and overall improved efficiency and automation. One of the main highlights of these projects for me is the overall performance of the rigs now that they have started up. The overall performance of the Bully and Globetrotter rigs has been very good, and the novel equipment such as the Multi Purpose Tower is working well. Delivering a project like this requires close cooperation between the equipment supplier, Huisman, the drilling contractor and the operator to ensure the rig is fit for purpose and delivers what we need from a modern deepwater rig.”

Late 2013 this was proven by the fact that the Bully I won the prestigious ‘Shell Floater Rig of the Year 2013’ and late 2014 the Bully II won the prestigious ‘Shell Floater Rig of the Year 2014’.

DRILLING

EXTREME DEEP WATER DRILLSHIP



DUAL MULTI PURPOSE TOWER

The vessels' distinctive feature is the Dual Multi Purpose Tower (DMPT). It has a welded box girder type load bearing structure with a hoist on either side. One hoist is situated above the well center in the drill floor on the forward side of the tower and the other above the center in the construction floor on the aft side. There is no lattice type derrick structure around the hoists, thus there is no V-door limitation, large objects can be skidded or hoisted with the cranes directly to the well centers or in the moon pool area.

The aft side of the tower is utilized for stand building while the forward side is utilized for (automated) drilling operations. The aft construction floor can be manned while on the drilling side dangerous operations are performed or when the drilling side is in auto-mode, since the tower acts as a barrier protecting the people on the aft side from hazard or automated machinery on the forward side. No 'Red zone' limitations are present. The construction side is also utilized for running of the BOP and risers. This can be done during drilling of the

surface hole from the drilling side. Further the handling of large subsea structures (e.g. X-mas trees) is performed on the construction side. The construction floor can be moved upwards in order to skid the BOP or X-mas trees to well center. The BOP or tree can be lowered into the water and the floor can be moved to its position. This eliminates the need for a large substructure height.

REDUNDANCY

The DMPT also has integrated redundancy, namely the dual drum drawworks, dual passive heave compensators and the pipe handling system. Should one of the winches or compensators fail, the other can still operate the traveling block at full load, however at half of the original speed or stroke. All machinery is mounted inside the tower, reducing the maintenance to a minimum. Both well centers can operate from the two setback drums. Also the setback drums are outfitted with redundant drives. Therefore the system is still fully operational should one pipe handling system fail.

SYSTEM



1.SPLITTABLE BLOCKS (2X)

Push button reeving change to increase block speed when handling lighter loads.

2.PIPE HANDLING SYSTEM

Efficient pipe handling system with two setback drums and eight manipulators.

3.DRILL FLOOR

Spacious drill floor fully enclosed by wind walls.

4.RISER TENSIONER SYSTEM

The system comprises twelve wire line type riser tensioners mounted vertical under the drill floor inside the hull.

5.PASSIVE HEAVE CYLINDERS

Two large cylinders with accumulators linked to the traveling block.

6.DUAL DRUM DRAWWORKS

Dual drum system with two fast lines with active heave compensation.

7.CONSTRUCTION FLOOR

The construction floor can be moved to skid the BOP or X-mas tree to well center.

8.SSBOP SKID CART (2X)

Brings the BOP into well center.

9.MOONPOOL SKID CART

Travels with a complete riser or tubular string hung off between both well centres.

10.X-MAS TREE SKID SYSTEM.

Bring X-mas trees into well center. Skid pallet skids onto moonpool skid cart.

DRILLING

EXTREME DEEPWATER DRILLSHIP



Innovative travelling block

INNOVATIVE PIPE HANDLING SYSTEM

The next generation automated pipe handling system incorporates small robust multi-functional manipulators which are mounted on rails built into the corners of the tower. The identical manipulators can be exchanged easily and can be maintained offline. The entire handling system is designed for a tripping speed of approximately 5,000 ft/hr.

The multi-functional manipulators are outfitted with quick connect heads. Tools can be exchanged quickly and without human interface. In this manner, the driller can always choose the right tool for the job and the tools which are not used can be maintained offline. On the drill floor two manipulators (identical to the manipulators for handling the pipe) are mounted. In this way two iron roughnecks are available at all times. The driller has one spare roughneck or he can use one for drill pipe with one for casing stand by.



Innovative skidding hang off table

INNOVATIVE TRAVELLING BLOCK

The travelling block is redesigned. The elevator, or pipe clamp, is no longer suspended on the topdrive but has its own suspension directly on the travelling block. In this way the topdrive is no longer in the heavy load path during lowering of very heavy strings. The topdrive can be less complex as it no longer needs to have pipe handling functions. This reduces the risk of dropped objects. Further, the topdrive can be removed and maintained during tripping. Also multiple pipe clamps can be stored underneath the topdrive allowing fast change overs from CSG to drill pipe or vice versa.

INNOVATIVE 'ROTARY' TABLE

The drilling system incorporates a new type of rotary table. The hang off table/power slip can skid away from the drill string while the string is suspended in the well center by the travelling block. The power slip can handle pipes up to 3.0 million lbs, from 3-1/2" up to 9-3/4" without changing inserts and can open up to 21". When skidding away a very large opening is created and thus large centralizers and other

SYSTEM



large objects can be lowered through without the need to remove bushings and adaptor rings. Conventionally, bushings and adaptor rings are removed by the drill crew with help of tuggers, leading to potentially dangerous situations. A second table can be setup for casing, allowing very fast change-overs from drill pipe to casing or casing to drill pipe. According Operators this will save approximately 5% time per well. As a back up standard adapter rings can be inserted to fit a conventional (power)slips.

HUISDRILL 12000

After the delivery of the two Globetrotters, Huisman further developed the design, resulting in the HuisDrill 12000. The HuisDrill 12000, as designed with Huisman's DMPT technology and unique construction methodologies, exceeds many of capabilities competing drill ship designs.

The Noble Globetrotter design is enlarged from 189m x 32.2m to 208m x 35.4m, increasing the payload from 20,000mt to 30,000mt. Also the tower capacity is upgraded from 2.4

million lbs to 3.0 million lbs. A work deck above the existing main deck is added, providing a very large open and available deck space (4,500m², 1-1/2 times of traditional drill ships). Further, the drill floor is now truly flush with the work deck enabling easy and safe transport of items and people to and from the drill floor and construction floor without any stairs. All fixed mounted equipment and rental equipment (such as: cement unit, ROVs, cuttings handling etc.) are located below the work deck. Also, all marine equipment (mooring gear, ventilation houses, loading stations, burner boom) are located under the work deck, providing true open and available deck space. Since almost all machinery is mounted in a protected environment, maintenance is largely reduced.

The vessel is capable of storing two large BOPs (up to 8 ram 20k 18-3/4" stacks) and a number of X-mas trees. She further can store and run 150ft riser joints speeding up the riser running process dramatically. In total 4,000m of risers can be stored allowing the vessel to operate in 'eXtreme Deep Waters' (XDW).

HUISDRILL

EXTREME DEEPWATER DRILLSHIP

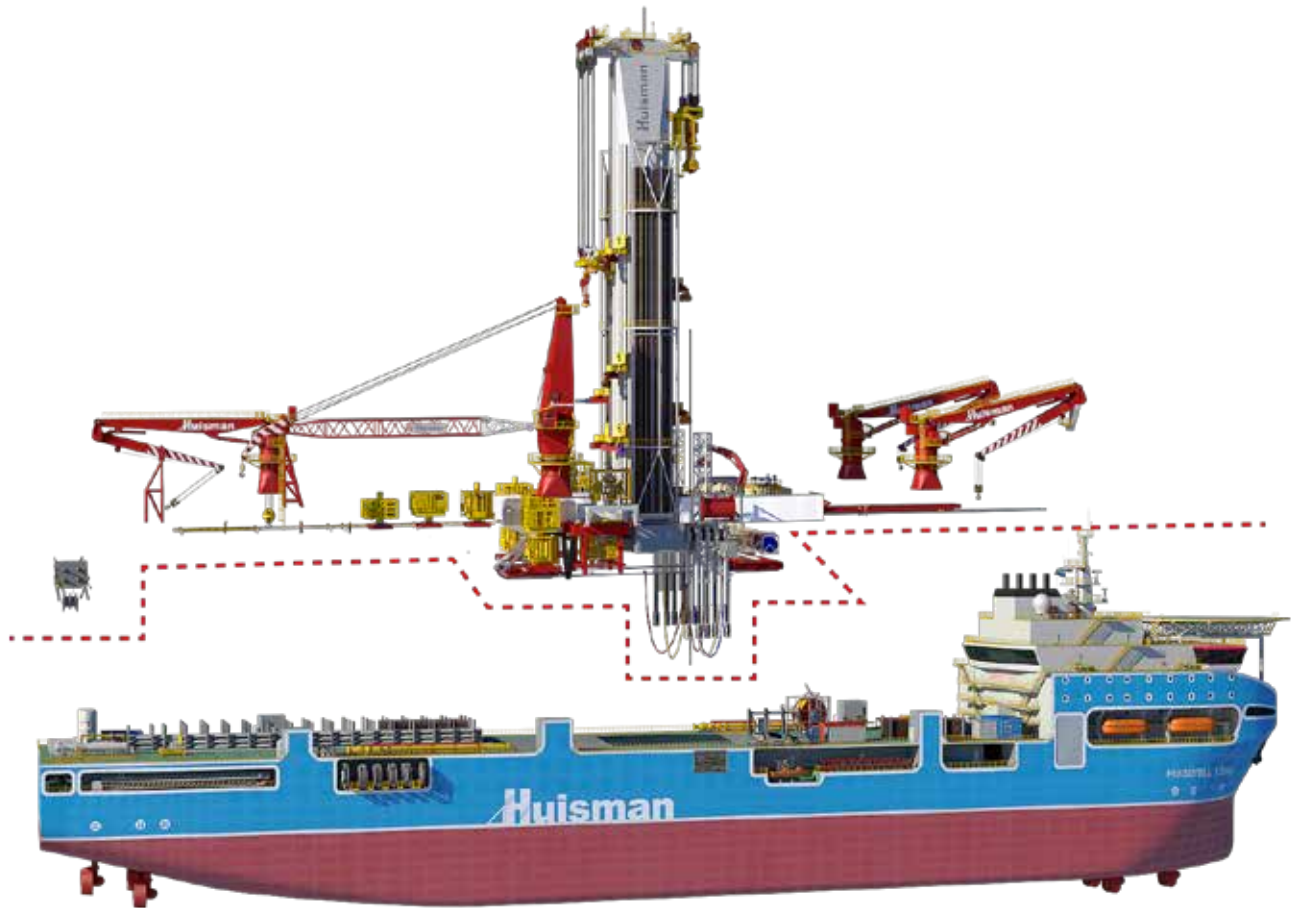

The vessel is equipped with 150ft risers (instead of 75ft or 90ft risers traditionally) minimizing the time for running risers. Also the number of leak paths is reduced providing less down time on the riser. The riser hold features two dedicated workshops for on-board inspection and maintenance of the risers. As an option the vessel can be outfitted with 75ft or 90ft risers. All risers are stored in a riser hold with overhead crane located under the work deck. Aft of the tower is a unique movable construction deck allowing efficient running of large subsea components as one piece.

The tower is lengthened and can handle 180ft stands (instead of 90ft or 135ft stands traditionally). This results in a higher tripping speed and less connections during drilling (thus less starting and stopping of the pumps resulting in improved wellbore stability).

Major oil companies and drilling contractors were consulted to incorporate solutions in the design, which will solve many of their common challenges and operational issues, providing

a step change in efficiency. With their input, the design of the drilling package, the functionality thereof and the material flows on board is optimised.

The design of the vessel is optimised to accommodate the following operations:

- Standard drilling operations
- Completion operations
- Work over operations
- Dual gradient drilling operations
- Managed pressure drilling operations

L 12000

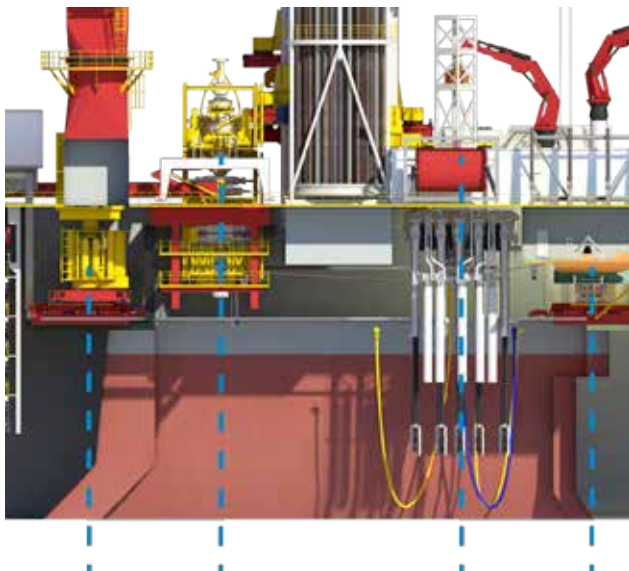

Four hang off points in moonpool



Traditional setup of RCD in moonpool



Heave compensated drillfloor

MOONPOOL

Two identical high capacity moonpool skid carts are installed in the moonpool area. Because of the recesses in the forward and aft moonpool wall the skid carts can skid with a string suspended beyond the drilling side and construction side, allowing hanging off strings at four locations, providing unprecedented functionality and capacity.

Possible operations:

Hang off point AFT of construction center for:

- Hang off riser and BOP for moving VXT to drilling well center.

Hang off point FWD of well center for:

- Hang off cuttings blower equipment.
- Hang off mud return lines from mud lift pumps.
- Hang off riser and BOP when landing HXT in drilling well center.

HEAVE COMPENSATED FLOOR

To enable MPD, DGD and Closed Loop drilling Huisman developed the Heave Compensated Floor. The heave compensated floor is a vertically movable floor which is guided by the travelling block rails and connected to the same heave compensators as the travelling block. This provides three big advantages:

- The drill string is heave compensated at all times (when suspended in the traveling block and in rotary table), eliminating swab and surge pressures in the hole and reducing wear of the RCD seals.
- No telescopic joint is required and the RCD can be mounted just below the rotary table, providing easier control and reducing the complexity in the moonpool area.
- Since the hole volume is made constant, kicks can be detected much faster and much more precisely.

HUISDRILL

EXTREME DEEPWATER DRILLSHIP

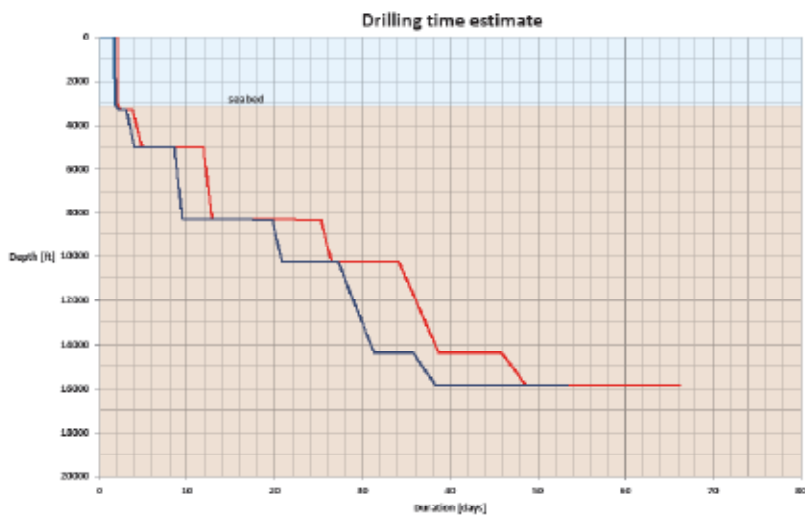

DWOP 1: Reduction from 66.2 to 53.4 days (-20%)

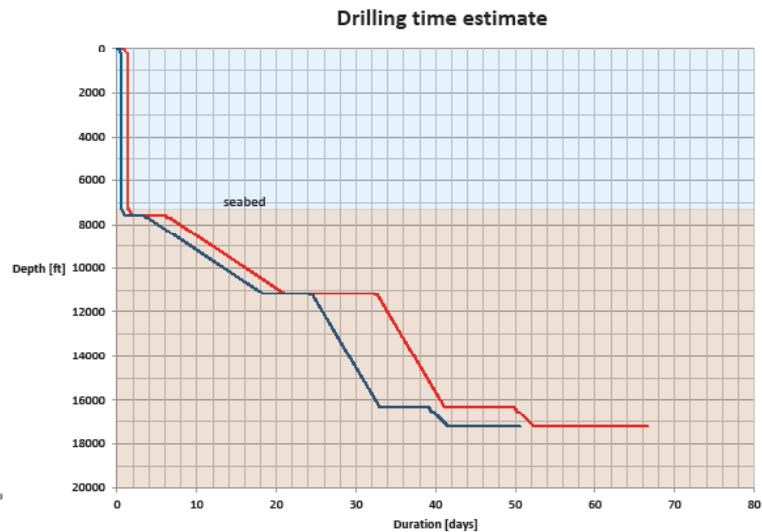

DWOP2: Reduction from 66.5 to 50.5 days (-24%)

EFFICIENCY

All these elements have resulted in a much more efficient unit. Since the vessel is 25-40% smaller than the competition, the OPEX is greatly reduced due to the smaller wind area and lower hull drag. By mounting almost all equipment inside, maintenance is reduced also resulting in lower costs. Together with the major oil companies and drilling contractors we have performed multiple "Drilling Well On Paper" (DWOP) exercises. The DWOPs have shown that the vessel can drill wells in 20-25% less time compared with other state of the art units, resulting in huge time and money savings.

The red line shows the time vs depth curve of a conventional UDW drill ship with a state-of-the-art dual activity derrick. The blue line shows the time vs depth curve of the HuisDrill 12000 with its DMPT technology. It is expected that the time saving will be even bigger when working in deeper waters.

L 12000



SAFETY

Safety has been taken as the core of the design. Several aspects improve the safety:

- The drill floor flush with the large open work deck:
 - Reduces the vertical movement of people and goods.
 - Reduces blind spots and improves better visibility.
- The DMPT with automated machinery:
 - Reduces the number of potential dropped objects significantly.
 - Physically separated drill floor and construction floor.
 - Reduces the amount of people on the drill floor to a minimum.
- Most equipment mounted inside:
 - Reduces people exposed to the environment.
- Well testing aft and engine rooms in the FWD end of the vessel:
 - No gas entering through ventilation to engine rooms.
 - Well testing as far away as possible from manned areas.
- Escape ways under main deck from stern to accommodation.



ANTI HEEL/ROLL COMPENSATION SYSTEM

In the aft end of the hull an anti heel/roll compensation system can be fitted. The system will actively keep the vessel horizontal, enabling fast pulling of tool joints through the power slips and reducing riser buoyancy damage.

HUISDRILL



L 12000



HUISDRILL 12000

Operational water depth: 4,000m (13,200ft)

Drilling depth: 15,240m (50,000ft)

Drilling mast: 2 x 1,360mt (3,000kips)

Stand length: 180ft

Riser length: 150ft

TEST TOWER



TEST TOWER

In the first half of 2015 a test assembly will be installed on Huisman's own premises in the Netherlands for testing and commissioning new drilling equipment. The system will be able to test drilling equipment.

MPT's variations like set-back and well center locations are possible to imitate on the test assembly. Rails have an equal interface as for an actual MPT, so actual traveling blocks and manipulators can be mounted.

For testing hanging-off a drill pipe or stand in the rotary (as with stand building), a hole in the ground underneath the well center will be drilled. Behavior of tubular and risers during tests is usable to improve equipment and the products as well.

Testing under an angle is made possible by tilting the test assembly. Dynamical ship movements can be imitated by rotating the tower side to side with desired frequency during operations.

TEST TOWER

Rated load	1,360mt	3,000 kips
Height	84 m	276 ft
Stand length	54.9m	180ft
Dual Drum Drawworks		
Static angle	5°	
Dynamic angle	+2°/-2°	

1. 3MLN LBS TEST TOWER

A full size steel structure capable of handling 180ft stands and 150ft riser.

2. TRAVELLING BLOCK

The test assembly can be equipped with a full size traveling block. This will be outfitted with the splittable blocks.

3. MANIPULATORS

On both sides of the tower manipulator rails are mounted. Different kind of tools can be mounted on the manipulators, like: grippers, iron roughnecks, riser make-up tools or man baskets.

4. SETBACK DRUM

A full set-back drum can be mounted on the set-back foundation on the base. On the tower are two heights on which the upper foundation can be connected, to fit two heights of set-back drums.

5. DRILL FLOOR & CONTROL CABIN

A control cabin will be used for controlling the equipment on the test assembly. Clear view on the test site is acquired by a window in the front and top. From the control cabin the drill floor, test MPT and set-back are visible.

6. DYNAMIC STRUT

Tilting of the test assembly is achieved by the dynamic adjuster. The dynamic adjuster is connected to the tower and the foundation.

7. HEAVE COMPENSATION

On the back of the test MPT supports are present to mount a heave compensation (active and passive) system.

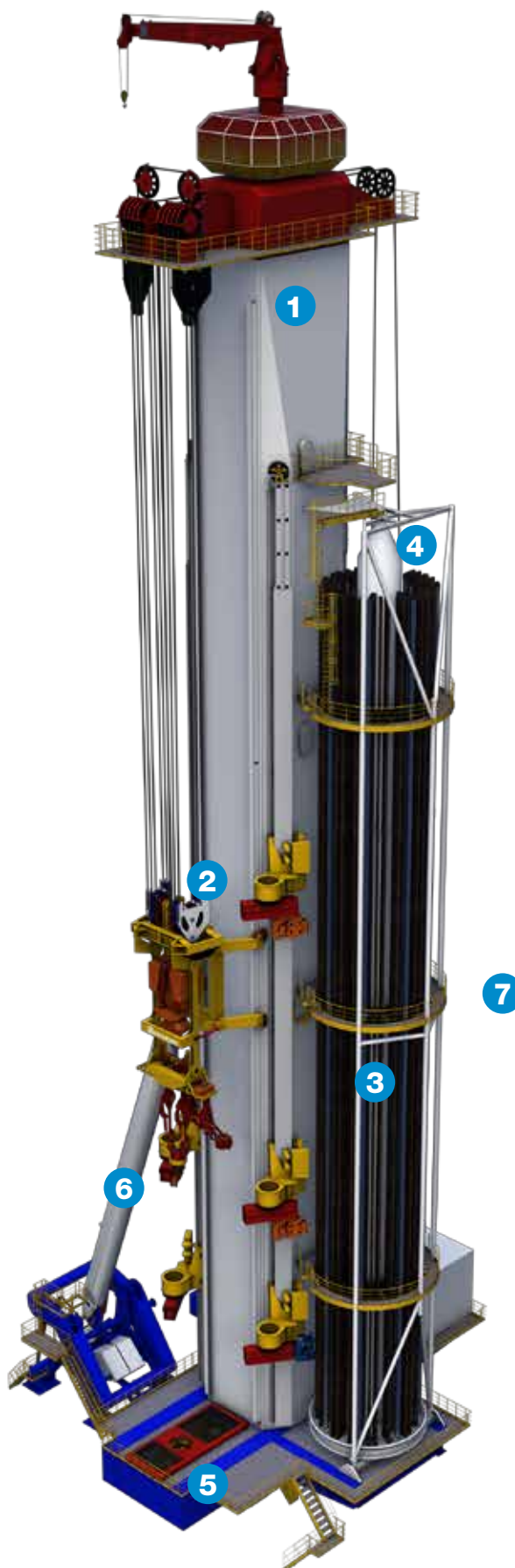

HUISDRILL

KEY CHARACTERISTICS

HUISDRILL 12000 - EXTREME DEEP WATER DRILLSHIP

Max. water depth	4,000m	13,200ft
Max. drilling depth	15,240m	50,000ft
Classification	ABS, +A1, (E), Drilling Unit, +AMS, +ACCU, +DPS-3, HELIDK-SRF, DNV (optional)	
Features	Exploration and development drilling, coiled tubing operations, installation of X-mas trees, well testing and completions	
Accommodation	240 persons	
Helideck	D22.8 m: S-92, EH101 or similar	

DIMENSIONS

Length overall	208 m	682 ft
Width overall	35.4m	116 ft
Depth to work deck	23.1m	76 ft
Deck space	4,500 m ²	47,400ft ²
Moonpool	27.2m x 11.2m	89 ft x 37 ft
Draught	12 m	39 ft
Payload/displacement	20,000mt / 60,000mt	
Payload/displacement	30,000mt / 70,000mt	

VESSEL

Power generation	6 x 6,500 kW	6 x 8,700 hp
Thruster (6 off)	min. 4,000 kW	5,400 hp
Optionally retractable FWD thrusters		
Service speed	11 knots	
Thruster control	DP 3	
No. of ROV's	max. 2 off	

DRILLING MAST – 3.0 MLN LBS, 180 FT STANDS

DMPT hookload	2 x 1,360mt	2 x 3,000kips	
Clear height	76.2m	250 ft	
Stand length	54.9m	180 ft	
No. of lines	20/16/12/8/4		
Drawworks MH	2 x 2,300kW	2 x 3,080 hp	
Drawworks CH	2 x 2,300kW	2 x 3,080 hp	
Heave compensation	1,360mt	3,000kips	
AHC stroke	8 falls 550 mt	7,0m	23 ft
PH stroke	8 falls 550 mt	6,0m	20 ft

MUD SYSTEM

No. of shakers	max. 2 x 5 off	
No. of mud pumps	max. 8 off	
Mud pump power	1,640 kW	2,200 hp

PIPEHANDLING

No. of manipulators	12 off	
Capacity manipulator (for 2)	13.6mt	30 kips
Setback stand length	54.9m	180 ft
Setback load capacity	1,630mt	1,800 sht
Setback capacity	DP up to 7"	50,400 ft
	CSG up to 16"	11,500 ft
Catwalk machines	2 off	

SKID CARTS

Moonpool skid cart	max. 2 off	
Max. capacity	1,360 mt	1,500 sht
BOP/LMRP skid cart	max. 2 off	
Max. capacity	550 mt	610 sht
X-mas tree pallets	max. 2 off	
Max. capacity	350 mt	385 sht

L 12000

RISER & BOP

Riser size OD	533.4 mm	21 inch
Max. riser length	45.7 m	150 ft
Storage (buoyancy OD 58")	4,000 m	13,200 ft
Riser tensioners	max. 12 off	
Rated capacity	2,180 mt	4,800 kips
Operational capacity (10 out of 12 x 90%)	1,630 mt	
No. of BOP's	max. 2 off	
BOP stack	max. 20,000 psi	18 ¾ inch

TANK CAPACITIES

Fuel oil	7,630m ³	48,000 bbl
Mud system	3,000m ³	19,000 bbl
Slug	32m ³	200 bbl
Pill	110m ³	700 bbl
Trip tanks	22m ³	140 bbl
Base oil	1,200m ³	7,500 bbl
Brine	1,350m ³	8,500 bbl
Trash	80m ³	500 bbl
Drill water	3,180m ³	20,000 bbl
Pot water	1,430m ³	9,000 bbl
Bulk	1,400m ³	49,400 ft ³
Urea	240m ³	1,500 bbl

CRANES

Knuckle boom cranes	3 off	
Supply boat lift cap.	100 mt @ 14m	110 sht @ 46 ft
Max. outreach	41 m	135 ft
PMOC aft SB	1 off	
Supply boat lift cap.	100mt @ 27m	110st @ 89 ft
Harbour lift cap.	300mt @ 15m	330st @ 49 ft
Max. outreach	48m	157 ft
Subsea capacity	85mt @ 3,000m	93sht @ 10,000 sht

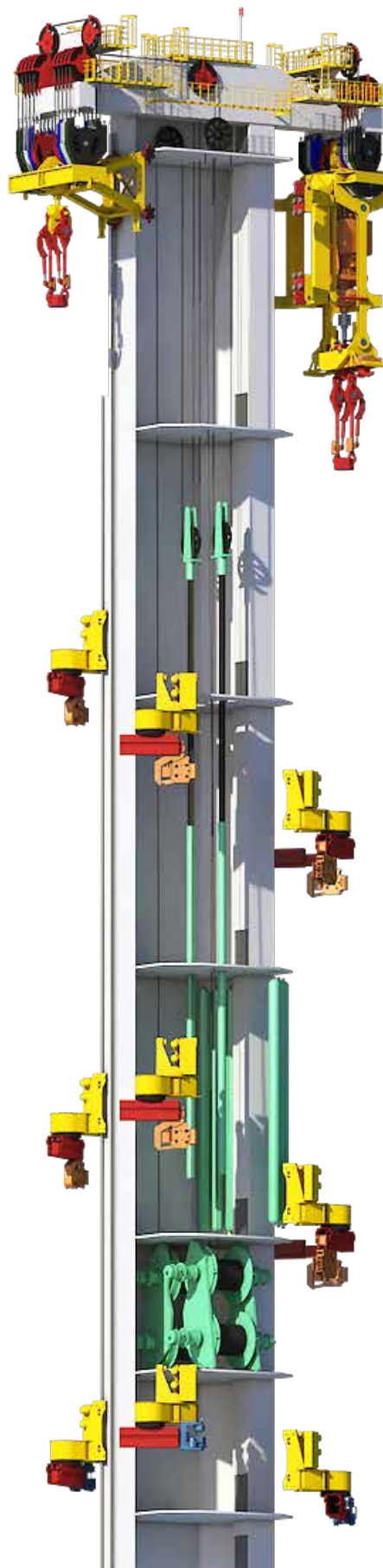

HUISMAN EQUIPMENT BV

Admiraal Trompstraat 2
3115 HH Schiedam
P.O. Box 150
3100 AD Schiedam
The Netherlands
Harbour no. 561

Phone: +31 (0)88 070 2222

Fax: +31 (0)88 070 2220

E-mail: info@huisman-nl.com

www.huismanequipment.com