

International Association of Drilling Contractors

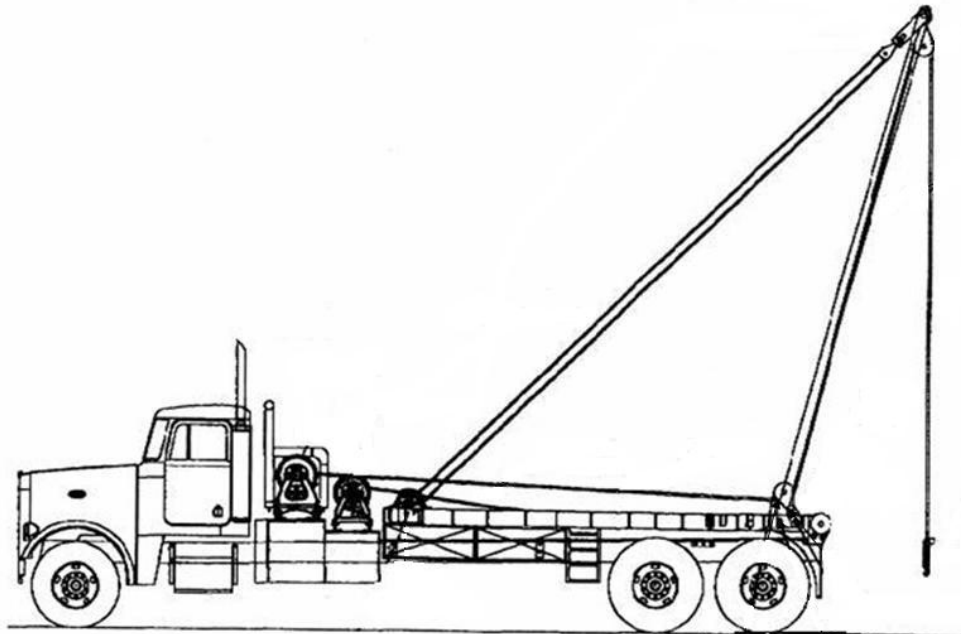

Oilfield Gin Pole Truck Guidelines



This page intentionally left blank.

SPECIAL NOTES

These voluntary guidelines contain recommendations from the IADC Rig Moving Committee and are established to give the drilling contractor and rig moving companies a basis on which to build and operate a Gin Pole Truck Guidance Program. Although these guidelines are voluntary consideration should be given to developing a in house program to meet the recommendations of these guidelines by April 1 2012.

IADC publications may be used by anyone desiring to do so. Every effort has been made by IADC to assure the accuracy and reliability of the data contained in them; however, IADC makes no representation, warranty, or guarantee in connection with this publication and hereby expressly disclaims any liability or responsibility for loss or damage resulting from its use or for the violation of any federal, state, or municipal regulation with which this publication may conflict.

No suggested method, practice, precaution or program set forth in this document shall be deemed to establish a legal standard of conduct or a legal duty, the violation of which would constitute negligence of any degree in any legal proceeding. IADC is not attempting to fulfill any duties or obligations of employers, manufacturers or suppliers to warn, properly train, or equip their employees or others who may be affected by their activities, concerning any health, safety, or environmental risks or precautions.

Nothing contained in this document is to be construed as granting right, by implication or otherwise, use of the IADC name, logo, or trademark, for the manufacture, sale, or use of any method, apparatus, or product.

Suggested revisions to this guidance are invited and will be considered along with future changes to these recommendations. Suggestions should be submitted to Joe Hurt International Association of Drilling Contractors, 10370 Richmond Avenue, Suite 760, Houston, TX 77042.

Copyright 2010 by the International Association of Drilling Contractors

FOREWORD

This guidance document is under the jurisdiction of the International Association of Drilling Contractors Rig Moving Committee. It was developed with assistance from the Association of Energy Service Companies (AESC). The goal of this voluntary guidance document is to assist the oil and gas industry in promoting safety in the exploration and the development of oil and gas. THE PUBLICATION DOES NOT, HOWEVER, PURPORT TO BE SO COMPREHENSIVE AS TO PRESENT ALL OF THE RECOMMENDED OPERATING PRACTICES THAT CAN AFFECT SAFETY IN OIL AND GAS DRILLING, WELL SERVICING AND PRODUCTION OPERATIONS.

IADC publications may be used by anyone desiring to do so. Every effort has been made by IADC to assure the accuracy and reliability of data contained in this document. However, IADC makes no representation, warranty, or guarantee in connection with the publication of this guidance and hereby expressly disclaims any liability or responsibility for loss or application hereunder or for any violation of local, state, or federal laws with which the contents may conflict. INFORMATION CONCERNING SAFETY AND HEALTH RISKS AND PROPER PRECAUTIONS WITH RESPECT TO PARTICULAR MATERIALS AND CONDITIONS SHOULD BE OBTAINED FROM THE EMPLOYER, THE MANUFACTURER OR SUPPLIER OF THAT MATERIAL, OR THE MATERIAL SAFETY DATA SHEET (MSDS).

Suggested revisions are invited and should be submitted to: International Association of Drilling Contractors.

CONTENTS

Page

1	Introduction	1
1.1	Scope	1
1.2	Policy Statement	1
1.3	Benefits of Oilfield Gin Pole Truck Guidelines.....	1
2	References	1
2.1	Industry Recommended Practices and Standards	1
2.2	Other References	2
3	Terms and Definitions	2
4	General Requirements	5
4.1	The ACT	5
4.2	Who is the Manufacturer?.....	6
4.3	Duties and Obligations	6
4.4	Incomplete Vehicle Document	6
4.5	Complete Vehicles.....	7
4.6	Manufacturer’s Requirements.....	7
4.7	Assembly Completion Sticker	7
4.8	Structural Modifications to Gin Pole Trucks	7
4.9	Design.....	7
4.9.1	Gin pole truck should be designed and the construction overseen by a qualified person	7
4.9.3	Truck Specifications	7
4.9.3.1	Truck Chassis Components	7
4.9.4	Winch.....	8
4.9.5	Bed Mounting	8
4.9.6	Gin Pole and Load Bearing Components Design	8
4.9.7	Snatch, Sheave and Cargo Blocks	9
4.9.8	Angle Factor & Block Loading.....	9
5	Inspection	11
5.1	General.....	11
5.2	Inspection Types.....	11
5.4	Inspection Documentation	13
	See Appendix “A” Sample Monthly / Annual Gin Pole Truck inspection Form.....	13
6	Repair and Maintenance	13
7	Training and Physical Fitness	13
8	General Information.....	14
8.1	Hazards The following is a general list of hazards that may be present in gin pole truck operations, but is not all inclusive.....	14
8.2	Operator General Information	14
8.3	Guidelines	14
8.4	Safe Working Procedures	15
8.5	Slings and Lifting Devices.....	15
8.6	Gin Pole Truck.....	16
8.7	Loads	16
8.8	Signals	17
	APPENDIX “A”	21
	APPENDIX “B”	22
	APPENDIX “C”	23

This page intentionally left blank.

1 Introduction

1.1 Scope

This publication applies to oil field gin pole trucks that may be utilized to pick up and / or move a load.

1.2 Policy Statement

These guidelines are intended to assist in improving safety, design, inspection, and operations of oil field gin pole and stinger trucks.

1.3 Benefits of Oilfield Gin Pole Truck Guidelines

Improve operational safety by providing guidelines to assist in the manufacture, repair, operations, and inspection procedures for oilfield gin pole trucks.

2 References

The most recent edition of the following publications have been used as references in the development of this guidance document.

2.1 Industry Recommended Practices and Standards

a) ASME International Standards Three Park Avenue, New York, NY 10016-5990

- ASME B-30.5-68 Safety Code for Crawler, Truck Cranes
- ASME B-30.6 Derricks
- ASME B-30.9 Basic Sling Operating Practices
- ASME B-30.10 Hooks
- ASME B-30.20 Below the Hook Lifting Devices
- ASME B-30.26 Rigging Hardware

b) American Petroleum Institute (API): 1220 L Street, NW; Washington DC 20005; www.api.org

- **RP 54:** Occupational Safety for Oil and Gas Well Drilling and Servicing Operations
- **RP 8 B:** Inspection, Maintenance, Repair, and Manufacturing of Hoisting Equipment
- **RP 9 B:** Application, Care, and Use of Wire Rope for Oilfield Service
- **API SPEC 9A:** Specification for Wire Rope
- **API RP 2D Appendix G C.5.1.2b** Commentary on Wire Rope and Sling Inspection, Replacement and Maintenance

c) International Association of Drilling Contractors (IADC): 10370 Richmond Avenue, Suite 760; Houston TX 77042; www.iadc.org

- Drilling Technology Series
- Health, Safety and Environment Reference Guide
- 52 Safety Topics
- Five Minute Rig Safety Meeting Topics
- Rules-of-Thumb for the Man on the Rig
- Safety Regulations for the Oil and Gas Industry
- The Rotary Rig and Its Components Poster
- Home Study Courses: Rotary Drilling Series
- Roughneck Training
- Safe Rigging Practices
- Basic Rigging Concepts

- Drums, Blocks, Sheaves, and Wire Rope Terminations
- Rigging Gear and Inspection Criteria
- Safe Rigging Practices and Procedures
- Putting Slings to Work

2.2 Other References

- 29 CFR 1910.180 Crawler, Locomotive, and Truck Cranes
- 29 CFR 1910.184 Slings
- Current chassis manufacturers' body builders guidelines.
- Ancillary Equipment manufacturers' guidelines
- Crane Manufacturers Association of America, Inc. Specification # 61
- ASTM A 391-01 Grade 80 Alloy Chain
- ASTM A 973 – 01 Grade 100 Alloy Chain
- ASTM A 906 Alloy Chain Slings
- AWS D1.1 Structural Welding Code.
- AWS D14.3
- SAE J – 706 Rating of Winches
- American Institute of Steel Construction (AISC)
- Z49.1: (R1999), Safety in Welding and Cutting and Allied Processes (AWS Z49.1)
- Cordage Institute of America

3 Terms and Definitions

3.1

Critical Area

highly stressed region of a primary load-carrying component as defined by the manufacturer or a qualified person.

3.2

Critical equipment

equipment and other systems determined to be essential in the load line of the truck hoisting equipment (winch, hoist line, hoist line accessories, hoist, hoist mounts, poles, pole mounts, pole lines, etc.).

3.5

Stinger Pole Truck

a winch truck equipped with stinger gin pole and hoisting equipment.

3.6

Design Factor

the ratio between the minimum (nominal) breaking strength and the rated load of the device.

3.7

Designated Person

a person who is selected or assigned by the employer or employer's representative as being competent to perform specific duties.

3.8

Fitting

an accessory attached to a wire rope.

3.10

Gin Pole Truck

a winch truck equipped with a pair of poles and hoisting equipment for use in lifting heavy machinery.

3.11

Gin Pole Truck Terminology

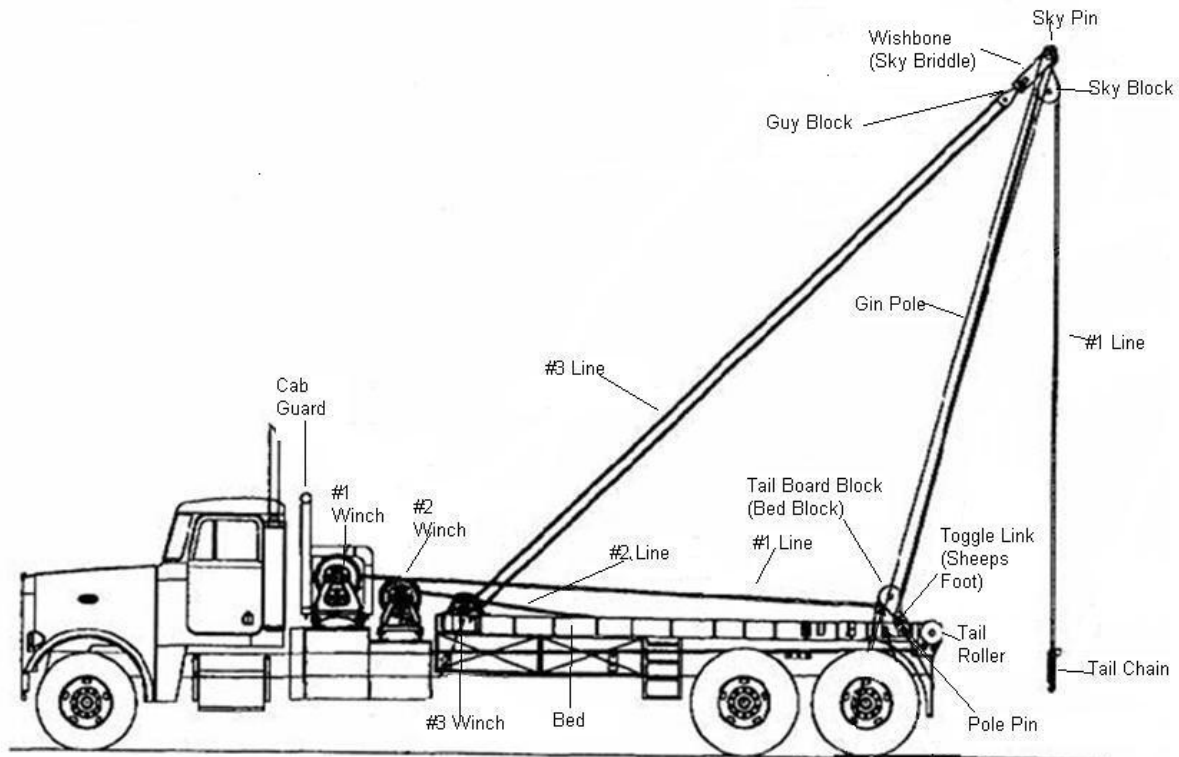

3.12

Hazard

any act or condition that if not corrected or noticed could lead to personal injury, equipment damage, or environmental consequences.

3.13

Hazard analysis

the application of one or more methodologies that aid in identifying and evaluating hazards. Sources that may be helpful in performing hazards analysis include IADC HSE Reference Guide.

3.14

Job Safety Analysis (JSA)

a documented process in which workers involved in or affected by the task systematically review the planned work, identify the hazards associated with that work, and implement safeguards to eliminate or mitigate those hazards prior to starting the work.

3.15

Lay Length

The distance measured parallel to the axis of the rope in which a strand makes one complete helical convolution about the core.

3.16

Lifting appliance

an appliance capable of being operated by mechanical, manual, or other means to raise or lower a load in a vertical or near vertical plane and includes any lifting tackle.

3.17

Lifting beams (Spreader beam)

a beam which carries loads from two or more points while being supported by one or more different points.

3.18

Lifting frame

a device made up of more than one lifting beam.

3.19

Lifting tackle

a sling, shackle, swivel, ring, hook, block or other appliance used in connection with a lifting device.

3.20

Location

the point at which a well is to be drilled, serviced, and/or produced from. Also referred to as "wellsite." It includes surrounding area used for storage and operation of ancillary equipment such as mud storage, tubing racks, erection of rigging equipment, maintenance areas, etc.

3.21

MBF - Minimum Breaking Force of Wire Rope

Is the published strength calculated by a standard procedure that is accepted by the wire rope industry. The wire rope manufacturer designs wire rope to this value and the end user should consider this value when making design calculations.

3.22

Mechanical splice

formation of loops or eyes in a rope by means of mechanical attachments pressed onto the rope.

3.23

Operator

a person qualified in the operation and use of the gin pole truck.

3.24

PPE

Personal Protective Equipment.

3.25

Qualified Person

a person who, by possession of a recognized degree, certificate, or profession standing, or who by knowledge, training, or experience, has successfully demonstrated the ability to solve or resolve problems relating to the subject matter, the work, or the subject.

3.26

Rigger

a qualified person who attaches or detaches lifting equipment and who has been instructed in the proper selection of slings and the slinging of loads, and who understands the capabilities of the lifting equipment with which he is working.

3.27

Rigging

the use of mechanical load-positioning equipment and associated gear to move, place, or secure a load including plant, equipment, or members of a building or structure and to ensure the stability of those members.

3.28

Rigging Rating

the working load limit of the rigging components.

3.29

Slings

an assembly fabricated from steel chain, wire rope, metal mesh, and natural or synthetic fibers which connects the load to the lifting device.

3.30

Supervisor

the person who has been given the control, direction, or supervision of work performed by one or more personnel.

3.31

Swage Fitting

Fitting into which wire rope can be inserted and then permanently attached by cold pressing (swaging) the shank that encloses the rope.

3.32

Swamper

a truck driver's assistant.

3.33

Tag line

a rope of suitable strength, construction, and length attached to the load which is used to assist in control of the load during lifting, lowering, or positioning a load.

3.34

Test certificate

a certificate issued by a qualified person or authority indicating that certain tests have been performed.

3.35

Third Party

the individual, partnership, firm, or corporation retained by the Operator to perform specialized services or to provide specialized equipment; does not include drilling or well servicing Contractors.

3.36

Winch Truck

a truck with one or more winches used in lifting, lowering or recovery of loads.

3.37

WLL: Working Load Limit

the maximum load which the product is authorized to support in general service when the pull is applied in-line (unless otherwise noted by manufacturer) with respect to the centerline of the product.

4 General Requirements

4.1 The ACT

FMVSS Certification: The National Traffic Motor Vehicle Safety Act (The Act) 49 USC 301, was passed by Congress in 1966 for the purpose of improving highway safety. To implement the act, Congress

empowered the National Safety Administration to enforce Motor Vehicle Safety Standards (FMVSS, Safety Standards or Standards) as contained in the Code of Federal Regulations (CFR), a Title 49 CFR Part 571, covers specifications with which a manufacturer must comply for building cars, trucks, buses, multipurpose passenger vehicles, trailers, and motorcycles. The standard also covers various equipment of components related to the safe operation of the vehicle, such as lighting, brakes, fuel system and cab or occupant safety. The Act also imposes notification, recall, and remedy obligations on manufacturers of motor vehicles.

4.2 Who is the Manufacturer?

For the purpose of the Act, a dealer, truck equipment distributor, or body/accessory manufacturer who installs a body or other equipment on an incomplete vehicle or who alters a certified completed vehicle before the first purchase of the vehicle in good faith for the purposes other than resale is deemed a “manufacturer” that must ensure the vehicle’s conformance with applicable Standards. NOTE: When the ultimate customer purchases an incomplete vehicle and installs additional equipment, the customer in effect, becomes a manufacturer and is subject to the certification requirements of the Act. This broad definition of manufacturing however, does not apply to all operations performed on a vehicle. For example, minor finishing operations such as painting are not considered manufacturing.

Every manufacturer is required by NHTSA (49CFR Part 566) to submit identifying information and a description of the items it produces. New manufacturers or those who make significant changes in their product lines must submit the information no later than 30 days after the start of alteration of production. This required information includes: (1) full individual, partnership, or corporate name of the manufacturer, (2) address of the manufacturer and state of incorporation if applicable, and (3) a description of each type of motor vehicle or equipment manufactured by the manufacturer, including the approximate ranges of Gross Vehicle Weight Ratings (GVWR) for each type of vehicle.

4.3 Duties and Obligations

Depending on the stage in the manufacturing sequence of the vehicle, manufacturers may be considered incomplete, intermediate, final-stage or altering manufacturers. Each type of manufacturer has certain obligations under the Act. The Act imposes three major duties on manufacturers of a new vehicle to be introduced into interstate commerce:

- a) They must build the vehicle in conformance with any applicable Safety Standards in effect on the date the vehicle is manufactured and exercise “due care” to ensure that when certified, each vehicle is in compliance with applicable Safety Standards.
- b) They must make available records, make reports when specified, and permit entry and inspection by authorized government officials.
- c) They must notify each purchaser and NHTSA of any Standard with which a vehicle fails to comply or of any safety – related defect in a product when it comes to their attention, and they must remedy any such failure to comply or any safety-related defect and keep certain records.

4.4 Incomplete Vehicle Document

All incomplete vehicle manufacturers must furnish subsequent stage manufacturers with an incomplete vehicle document (IVD) that contains the information required pursuant to 49 CFR Part 568.4. The IVD must remain with the incomplete vehicle through all intermediate manufacturing operations and is to be removed only by the final-stage manufacturer. If changes in the vehicle made by the intermediate manufacturer(s) affect the validity of the statements contained in the incomplete vehicle manufacturer(s) IVD, the intermediate-stage manufacturer must provide an addendum to the document that contains intermediate-stage manufacturer’s name, mailing address and indication of all changes that should be made in the IVD to reflect the changes made to the vehicle.

Incomplete and intermediate-stage manufacturers of chassis-cab (chassis-cab is defined in 49 CFR Part 567.3 as “an incomplete vehicle, with a completed occupant compartment, that requires only the addition of cargo-carrying, work-performing, or load-bearing components to perform its intended function”) are required under this part to affix to each chassis-cab an appropriate certification label upon completion of their manufacturing operation.

4.5 Complete Vehicles

Vehicles must have a final-stage certification that meets federal and state requirements.

4.6 Manufacturer's Requirements

Every effort should be made to comply with each manufacturer's standards.

4.7 Assembly Completion Sticker

When a gin pole truck is completed, the manufacturer should affix a Assembly Completion Date sticker to the unit. The data and information to be provided on the Assembly Completion Date sticker should include, but not be limited to the following:

- a) Assembly Completion Date of Winch Truck
- b) Truck Make:
- c) Truck Model:
- d) Bed serial Number:
- e) VIN Number:
- f) Rated working load:

4.8 Structural Modifications to Gin Pole Trucks

When structural modifications are made to a gin pole (stinger) truck, a qualified person shall establish the ratings, operating limitations, maintenance, testing, and inspection requirements that apply to the structurally modified truck.

A new Assembly Completion Sticker needs to be attached to the gin pole truck.

4.9 Design

4.9.1 Gin pole truck should be designed and the construction overseen by a qualified person.

4.9.2 Gin pole truck working load rating

4-9.2.1 The gin pole truck rating should be developed under the guidance of a qualified person. This rating should be based on the ratings of the OEM of purchased parts and analysis of the built parts by a qualified person and a lift test.

4.9.3 Truck Specifications

The truck chassis should be selected based on the working load limit that the end user anticipates. Items that need specifications are:

4.9.3.1 Truck Chassis Components

- a) Manufacturers' Frame Specifications;
- b) Manufacturers' Engine Specifications;
- c) Manufacturers' Transmission Specifications;
- d) Manufacturers' Axle(s) Specifications;
- e) Manufacturers' Suspension Specifications;
- f) Manufacturers' Tire(s) Specifications;
- g) Manufacturers' Wheel(s) Specifications;

A technical drawing of the truck should be included in the chassis documentation.

4.9.4 Winch

a) Winch Size

Winch selection should be made based on the working load limit of the truck. Winch ratings should be published for the winch rated line pull and designed to conform to or exceed the requirements of SAE J706. Follow the manufacturers' recommendation to ensure that the appropriate winch is chosen.

b) Winch Mounting

The mount must be flat to insure proper alignment between the gearbox side, the drum, and the clutch.

- The winch should be mounted perpendicular to an imaginary line from the center of the cable drum to the first sheave or load to ensure proper fleet angle and even cable spooling.
- The winch mount should be securely mounted to the vehicle frame in a manner acceptable to the vehicle manufacturer.
- The rule of thumb to use when selecting cap-screws to mount the winch is to use the same size and number of cap-screws to fasten the winch to its mount as the manufacturer uses to fasten the gearbox and end bracket to the winch frames.
- Winches must never be fastened to the frame of the truck. Mounting brackets must be used.
- The mounting span must comply with the winch manufacturer's recommendation.

c) Winch and Gin Pole Wire Rope

- Winch Wire Rope: Follow the winch and the wire rope manufactures' recommendations.
- Tail Chain: Follow the manufactures' recommendations.
- Gin Pole Guy System: Follow the manufacture's recommendations.

Wire Rope strength should be determined based on manufacturers' specifications considering reductions due to bending and attachments. The minimum design factor for six strand wire rope used for hoisting should be 3.5

4.9.5 Bed Mounting

Most truck manufacturers publish a body builder's guide to aid the installer in mounting of allied equipment to the truck chassis. There are also professional organizations like National Truck Equipment Association (NTEA), who have published basic guidelines for body mounts.

There are three basic types of body mounts; flexible, rigid, and combination. Rigid mounts should be used at the rear of the bed and flexible mounts should be used at the front.

a) Clamp/Bracket Type – Rigid

b) Shear Plate Type – Rigid

c) Spring Type – Flexible

d) Bolt/Bracket Type – Semi Flexible

e) U – Bolt Body Mountings. Even though U-Bolt body mountings are popular they are among the least effective mounting systems. If they are used, proper frame spacers must be used. Some of the problems are: loosening, not preventing forward movement of the body, and frame damage.

4.9.6 Gin Pole and Load Bearing Components Design

Components may include: Header Pin (Sky Pin); Foot Pin Design; Pole Design

Gin Pole and load bearing components should be designed and constructed to withstand stresses imposed when properly installed and handling loads not exceeding the manufacturer's load ratings under normal operating conditions. The structural components should be designed in accordance with recognized codes for steel construction such as American Institute of Steel Construction(AISC) codes . Welding of load bearing members shall conform to recommended practices of the American Welding Society as outlined in ANSI/AWS D14.3 or ANSI/AWS D1.1.

4.9.7 Snatch, Sheave and Cargo Blocks

- Rigging Blocks should be selected according to the manufacturer's recommendation based on the anticipated Working Load Limit.
- The WLL and manufacturer's identification must be permanently marked on blocks.

4.9.8 Angle Factor & Block Loading

The angle between the ropes passing around the blocks must be considered when rigging up a winch truck and in the operations of the truck.

Due to the Angle Factor Multiplier, the total load on the block can be greatly different from the load on the lead line. For example at 0 degrees (180 degrees wrap of rope), the multiplier is 2. As the angle increases the angle factor decreases and at 120 degrees the multiplier is 1.

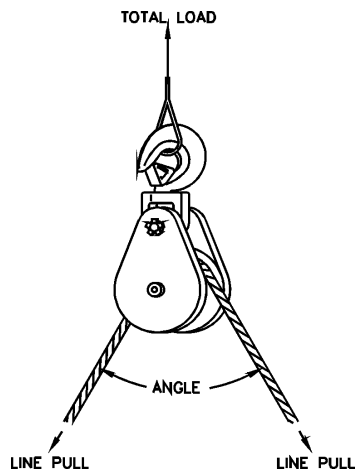

Angle Factor Multipliers			
Angle	Factor	Angle	Factor
0°	2.00	100°	1.29
10°	1.99	110°	1.15
20°	1.97	120°	1.00
30°	1.93	130°	0.84
40°	1.87	135°	0.76
45°	1.84	140°	0.68
50°	1.81	150°	0.52
60°	1.73	160°	0.35
70°	1.64	170°	0.17
80°	1.53	180°	0.00
90°	1.41	—	—

Special Precautions: Gin Pole trucks have unique features that require special precautions when operating. It is important to remember to follow the manufacturer's recommendations (loading specifications) for winches, blocks, hook attachments and wire rope.

Note: When raising the poles off the tailboard, it is imperative that the tailboard block be positioned and loaded in a manner that insures the resultant force is applied in a direction that is above and behind the pivot point (rearward) of the pole pivot point. Otherwise the poles will not raise and severe overloading of hoisting system will result.

a) **Small winch line angles create great forces on blocks**

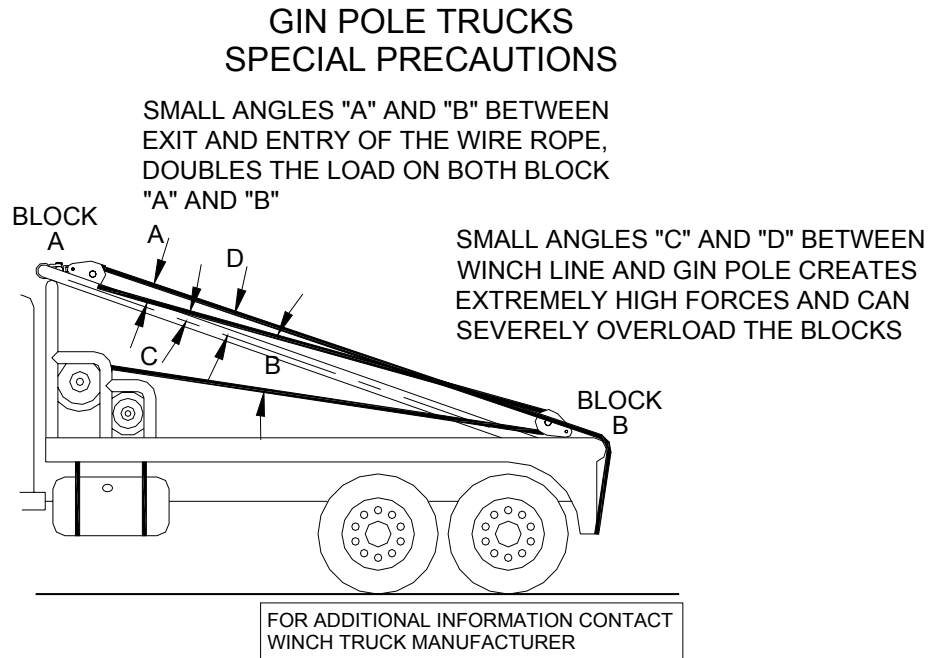

b) **Increasing the angle will decrease loads on blocks and winching system**

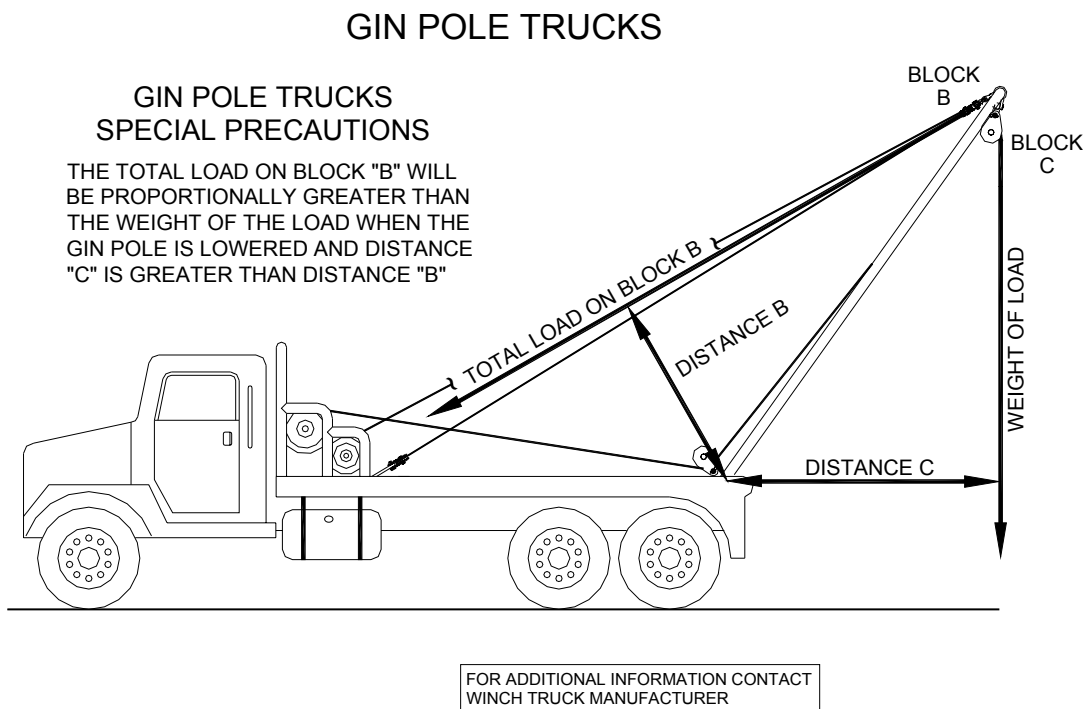

c) **Lowering the poles increases the load on the main hoisting block**

5 Inspection

5.1 General

Gin pole trucks lift large amounts of weight and transport over long distances. Equipment safety and reliability cannot be ensured unless it receives regular inspections. Inspection provides a means of detecting potential hazards that could contribute to accidents.

Assembly drawings, drawings identifying critical areas, and acceptance criteria should be available for the inspection. In the absence of critical area drawings, areas of primary-load-carrying components should be considered critical. This data should be used by the inspector to adapt the inspection procedure. In addition, the users / owners may provide the history of repair, if available.

Welds in critical areas should be inspected.

New lifting appliances should have manufacturer's documentation. Repaired, redesigned, or modified appliances should be proof tested before putting into service. The proof load documents should be retained.

Additionally, depending upon the severity of use periodic inspections, and if necessary load tests, should be performed and documented on lifting devices, according to the manufacturer's recommendations.

5.2 Inspection Types

- a) **Initial Inspection:** Prior to initial use, new, reinstalled, altered, or modified trucks should be inspected by a qualified person.
- b) **Prior to Use Inspections:** Visual examinations by the operator or other designated personnel with records are not required. At a minimum, the following items should be visually checked:
 - 1) Working Lights in place - clean and operational
 - 2) Back-up Alarm in place and operating
 - 3) Front Suspension free of cracks and damage
 - 4) Front Tires properly mounted, inflated and free of damage
 - 5) Front Wheel Assembly properly mounted and free of cracks and damage
 - 6) Rear Suspension free of cracks and damage
 - 7) Rear Tires properly mounted, inflated and free of damage
 - 8) Rear Wheel Assembly properly mounted and free of cracks and damage
 - 9) Winch mounts free of cracks and damage
 - 10) Bed free of cracks (fifth wheel and or pin, headache, etc.)
 - 11) Gin Poles free of cracks and excessive wear
 - 12) Lower Gin Pole pins and securment devices free of cracks and excessive wear
 - 13) Sky Pin free of cracks and excessive wear
 - 14) Sky Bridal / Wishbone free of cracks and excessive wear
 - 15) Tailboard Block(s) free of cracks and excessive wear
 - 16) Toggle Link(s) free of cracks and excessive wear
 - 17) Sky Block(s) free of cracks and excessive wear
 - 18) Bottom Guy Block(s) free of cracks and excessive wear
 - 19) Top Guy Block(s) free of cracks and excessive wear
 - 20) # 1 Winch Line (active portion) free of damage
 - 21) # 2 Winch Line (active portion) free of damage
 - 22) # 3 Winch Line (active portion) free of damage
 - 23) Tail chain(s) free of cracks and excessive wear
 - 24) Winch Line Termination Device free of cracks and excessive wear
 - 25) All Lifting Slings and Bridles tagged and free of excessive wear
 - 26) Winch Controls in working order, properly mounted and free of damage
- c) **Monthly Inspections:** Inspection by a qualified person making records of apparent external conditions to provide the basis for a continuing evaluation. If a winch truck is idle for six months or more, the monthly inspection should be completed prior to putting into service. See Appendix "A"
- d) **Annual Comprehensive Inspections:** This inspection will include disassembly of critical components to be non-destructive testing (NDT). NDT documentation is to be attached to the Annual Comprehensive Inspection form. See Appendix "A"
- e) **Incident / Severe Service Inspections:** These inspections are necessary whenever incidents occur which apply sudden and unusual shock loads, unusual stress or possible damage, due to any cause.

Such incidents which affect the safe operation of the unit should be followed by an immediate and thorough inspection. Damage must be repaired before equipment is returned to service.

- f) **Fire and Heat Exposure:** Following any exposure to temperatures exceeding 400 degrees Fahrenheit, the affected areas of the structure should be inspected for distortion. Exposure to heat, above the critical temperature of the grade of steel, warrants further examination of the affected area by a qualified person.

5.3 Components to be Inspected:

Components that have a direct bearing on the safety of the winch truck and whose status can change from day to day with use, should be inspected, and when possible, observed during operation for any defects which could affect the safe operation of the unit. These components include:

- a) Control mechanisms;
- b) Winches;
- c) Winch drives;
- d) Winch lines; When determining the need to retire wire rope the following statements need to be considered:
 - Wire rope that makes up the active system that has crushing, three broken wires in one strand in one lay length (lay length is the distance for the strand to go around the wire rope) or six random broken wires in one lay length, bird caging or kinking should be retired.
 - When inspecting wire rope on the winch drum consideration must be given to inactive wire rope and active wire rope.
 - Inactive wire rope is rope that is retained on the drum and is **never involved** in hoisting the load. Inactive wire rope is wire rope that is on the drum including rope in the anchor to **no less than five wraps** from the line leaving the drum going to the hoisting or pulling system. Operators and riggers must understand that this point can move as the length of line from the winch to the load increase or decreases. Allowance for flattening and /or broken wires in the inactive area can be made as long as the operator understands that at no time should the damaged wire rope be part of the Active Wire Rope system.
 - Active wire rope includes wire rope from the chain (hook) end through the winch truck sheaving and including the first five wraps on the drum. **Wire rope that has crushing, broken wires has no known breaking strength, therefore no working load limit and must not be utilized as part of the active wire rope system.**
- e) Load block components such as Blocks (snatch, sheave, cargo),
 - For corrosion;
 - For deformation;
 - For sheave and pin wear;
 - For misalignment or wobble in sheave and to ensure the sheave freely turns;
 - To ensure that snatch block retaining pins correctly retain the gate assembly;
 - Security of nuts, bolts and other locking methods; and
 - Excessive wear and clearance of fittings.
- f) Gin Poles, Sky pins, Toggle Links, Gin Pole pins and feet, Gin Pole cable top attachment device.
- g) Critical welds;
- h) Axles, suspension, wheels and tires.

5.4 Inspection Documentation

See Appendix “A” Sample Monthly / Annual Gin Pole Truck inspection Form.

A list the sheaves, pins, wire rope, and end fittings and their rated capacities should be available during the inspection.

6 Repair and Maintenance

- 6.1** Welding in critical areas (if allowed by the manufacturer) should be done in accordance with ANSI/AWS D1.1 Structural Welding Code.
- 6.2** Repairs should be carried out to the manufacturer’s specifications or qualified person’s recommendations.
- 6.3** Worn or damaged parts that cannot be repaired to original specifications should be replaced with parts at least equal to original manufacture’s specifications.
- 6.4** Repairs to critical areas should be documented.
- 6.5** Equipment components should be maintained as per the manufacturer’s recommendations if available.

7 Training and Physical Fitness

7.1 Physical fitness of Gin Pole Truck operator:

Gin Pole Truck operators should be physically fit to drive a commercial vehicle. Some items that should be included in their physical exam are:

- Vision test
- Be able to distinguish colors
- Normal depth perception, field of vision
- Negative results to a substance abuse exam
- Manual dexterity / coordination

Note: A DOT Physical for a commercial driver’s license is acceptable indication of a gin pole truck operator’s fitness for duty.

7.2 Gin Pole Truck Operator Training:

The gin pole truck operator should be trained in the aspects of inspection of the gin pole truck rigging, hoisting and movement of loads the gin pole truck is expected to handle. This training should be documented.

7.3 Swamper

Swampers should receive training in safety issues related to tasks they may be required to carry out on the job site. This training should be documented.

7.4 Rigger

Riggers should receive training in rigging loads. Training should also include safety issues related to working around hoisted loads as well as working around hoisted loads being moved. This training should be documented.

8 General Information

8.1 Hazards The following is a general list of hazards that may be present in gin pole truck operations, but is not all inclusive.

- a) Suspended loads could fall on personnel or equipment
- b) Wire ropes, chains or slings under tension could fail, striking personnel or equipment
- c) Winch could be overloaded and fail
- d) Gin poles / wire rope could touch overhead electrical power lines.
- e) Shock loading (sudden lifting and/or releasing of the load) could overload equipment causing failure.
- f) Severe angle loading resulting in over stressing of rigging gear or poles.
- g) Failure to use a spotter when backing could result in backing into personnel or equipment.
- h) Pins used to attach blocks could shear and fly a distance.
- i) Pulley shaft pins could fail.
- j) Ground stability and degree from level.
- k) Adverse weather conditions.
- l) Body positioning.
- m) Pinch Points

8.2 Operator General Information

Gin Pole and Stinger Trucks along with winches and slings used to lift loads should be operated by only one of the following:

- a) Operator – A person qualified in the operation of the winch truck.
- b) A trainee under the supervision of a designated person or Operator.
- c) Designated Maintenance, test personnel and inspectors, while performing their duties.

8.3 Guidelines

a) General (For all types hoists, gin pole trucks, slings)

- Personnel should stand clear of the load, and never be between the load and another object, or beneath the load.
- When loads are being lifted, all personnel should stand clear of the load line path and be clear of the direct line from the block shafts.
- All personnel on location should be instructed as to the driver's visual area so that they do not walk into a blind area as the truck is moving.
- When placing the winch truck in position to tie onto a load, all personnel are to stay clear of the path of the truck and must not place themselves between the winch truck and load. **(Stay out of pinch points)**
- Placing hands on loads should be avoided. Where loads have to be physically guided or stabbed into place by hand, precautions shall be implemented to minimize exposure to personnel.
- Personnel should keep hands off of lifting lines while the winch is engaged.
- A suspended load should never be moved above any personnel.
- Loads should be centered with the load line.
- Lift the load a few inches to observe the balance if necessary to reset the slings lower the load to the ground and reset slings to balance load.
- Make sure the rigging controls the load.

- Ensure rigging is properly attached to the winch line.
- While utilizing gin pole trucks to hoist and move loads, refer to the required clearances indicated in the following chart. This clearance is from the gin pole truck poles or any object protruding or suspended from it.
 - **50kV or below** **10 feet**
 - **>50kV to 200kV** **15 feet**
 - **>200kV to 350 kV** **20 feet**
 - **>350kV to 500 kV** **25 feet**
 - **>500kV to 750 kV** **35 feet**
 - **>750kV to 1,000 kV** **45 feet**

8.4 Safe Working Procedures

- a) Gloves should be used when working with wire rope.
- b) Hand signals should be discernable and consistent. (Refer to 8.8.1 and 8.8.2)
- c) Only one person should be designated as the signal person to the operator.
- d) Movement of the load should not occur until all personnel have moved out of the path of the load and the signal person is within sight of the driver.
- e) Operator should obey an emergency stop or stop signal by anyone.
- f) Use radio communication in addition to hand signals, if applicable.
- g) When a lift is in progress, the operator should neither perform any other work or leave the controls until the load has been safely landed.
- h) Oil field gin pole trucks should not be used for raising or lowering personnel.
- i) No one should ride on the outside of trucks or on loads, buckets or hooks suspended from gin poles.
- j) Evaluate safety considerations during lifting operations when wind speeds are excessive.
- k) When more than one winch truck and/or other equipment are needed to lift/move the same load, coordination between operators, swampers and other personnel is essential preferably using a JSA.

8.5 Slings and Lifting Devices

- a) When lifting an object, proper lifting device(s) and rigging procedures should be followed.
- b) Visually inspect slings per B-30.9 or 1910.184 Slings.
- c) A documented sling and lifting device inspection should be conducted on a annually basis. Sling and Lifting Devices inspections should be documented.
- d) Do not inspect a wire sling by passing bare hands over the sling.
- e) Provide suitable protection from sharp edges.
- f) Avoid kinks, loops, or twists in the legs of the sling.
- g) Keep hands, fingers, feet and body parts, from between the load line or sling and the load.
- h) Start the lift slowly to avoid unnecessarily stressing or shocking the sling or lifting device.
- i) Block up the load to allow space to remove the sling. Do not pull slings from under a load when the load is resting on the sling.
- j) Do not shorten a sling by knotting or twisting.
- k) Eyes in slings should not be formed by wire rope clips or knots.
- l) Keep wire rope slings well lubricated to prevent corrosion. Use the manufacturers recommended lubricants.

- m) Synthetic slings that do not meet standard requirements (29 CFR 1910.184) should not be used until repaired by a sling manufacturer or equivalent entity. If not repairable, destroy them.

8.6 Gin Pole Truck

- a) Consider the dynamic effects of moving the truck with a suspended load.
- b) Ensure that poles are evenly anchored and positioned.
- c) Do not stretch winch lines across a road or street without roadblocks.
- d) Attach slings to load so that the horizontal angle between the sling and the load will not be less than 30°.
- e) Secure the load before moving the truck. Minimize the distance that suspended loads are carried.
- f) Stand clear and keep fingers clear whenever tension is being applied to a winch line.
- g) Slowly take up slack in the winch line.
- h) Never let the winch line pass or slide through your hands.
- i) Spool the line evenly on the winch line drum to prevent line tangles on the drum.
- j) Lift the load a few inches to observe the balance and reset slings to balance load.
- k) Loads should be powered up or down with the winch.
- l) Ratchet binders provide improved mechanical advantage over single cam type binders and are becoming more prevalent in the industry. If using cam type boomers for load binders they must be released carefully. Stand clear of the binder handle when releasing the tension. Keep yourself out of the path of the moving handle and any loose chain laying on the handle. It is important to read and understand the manufacturer's application recommendations.
- m) Secure the winch line to the truck bed and disengage the winch line drum drive when not in use.
- n) Keep fingers clear of the tailboard when securing the winch line hook.

8.7 Loads

For drilling and service rig applications, equipment can be classified into the following categories:

- Skidded and Enclosed Loads (e.g. pump houses, light plants, etc.)
- Skidded and Non-enclosed Loads (e.g. mud tanks, centrifuges, etc.)
- Non-Skidded Loads (e.g. matting, junk boxes, drill pipe, drill collars, etc.)

8.7.1 Skidded and Enclosed Loads:

These loads may be moved providing that reasonable attempts have been made to secure items inside the building or skid. Additionally, it must be ensured that items not secured inside the building would not affect the stability and maneuverability of the vehicle in the event of an overturn. Anything with weight or mass sufficient enough to accomplish this would have to be fully secured within the skid or building. Alternatively, posts or pins can be also used to secure equipment with these buildings as long as the securement device is of sufficient height and strength. The rule of "flush or higher" should be used in accordance with this type of securement. This rule requires that these securement devices (pin or post) must be at least as high, if not higher, than the equipment being secured.

8.7.2 Skidded and Non-Enclosed Loads:

These loads must be secured so that nothing can be lost from the load. Additionally, loads can be transported without a cover, provided that the walls of the container are higher than any part of the load and that the load itself is of sufficient weight to remain in the container in the event of contact or rollover. Equipment or material that can be secured within the skid or non-enclosed load should be secured.

Another option is to consider is the use of "Sea Containers" on skids when shipping miscellaneous equipment.

8.7.3 Non-Skidded Loads:

These loads will be the most problematic because the equipment being moved was not designed or constructed with transportation securement in mind. The equipment is designed for specific field use, and as such, will not easily meet the requirements for securement. The primary concerns with these loads are loose pieces that do not fit anywhere else. Loose equipment such as planks, flare lines, valves, etc. will have to be independently secured or added to a different load where it can be secured.

8.8 Signals

A copy of the hoisting and truck movement signals should be available at the job site.

8.8.1 Hoisting Signals (See appendix B)

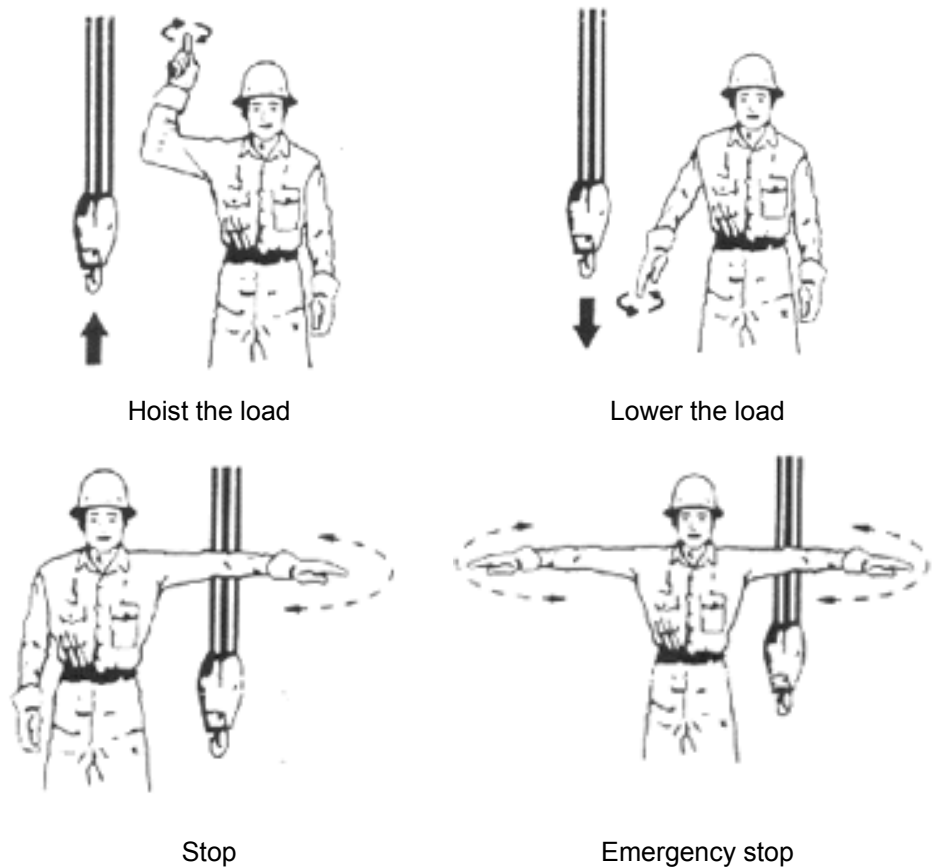

8.8.2 Truck Movement Signals: (See Appendix C)

a) Proceed Slowly – Straight Forward or Backward:

Both arms extended forward and slightly wider than the body, parallel to the ground. Palms facing the direction of desired travel. Together bend both arms repeatedly toward the head and chest then extend. To signal to stop truck movement - stop movement of the arms and grip the hands into fists [see “d”) below].



FORWARD: Palms facing away from body. Move arms forward (from raised position down to chest level and back to raised position.



BACKWARD: Palms facing toward the body. Move arms from chest level to raised position then back to chest level position.

b) Turn:

The direction arm is extended from the side of the body, parallel to the ground with fingers indicating the direction the vehicle or equipment is to travel. Motion with the arm moving slightly up and down bending at the elbow. To stop the truck turning movement grip the pointing hand into a fist.



TURN TOWARD DRIVERS RIGHT



STOP TRUCK TURNING

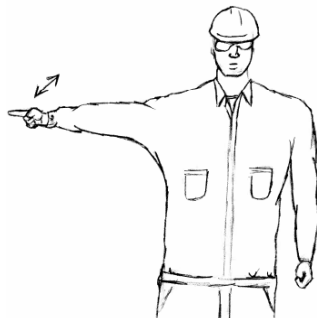

TURN TOWARD DRIVERS LEFT

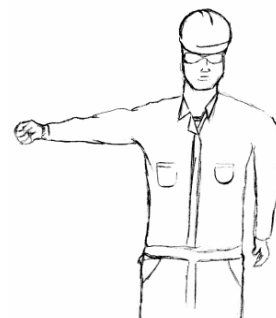

STOP TRUCK TURNING

c) Distance to stopping point:

To give the driver a visual reference for the distance to the stopping point, with both arms extended sideways with elbows bent upward at 90 degrees. Palms facing forward. Keep hands above head and bring elbows forward as the distance narrows. As elbows reach the straightforward position, continue the hands coming together above the head to indicate the stop point is being reached. Upon reaching the stopping point, give the STOP signal.



d) Stop:

To stop all movement of the vehicle and await further instructions, grip the hands into a fist.



f) Vehicle is clear to leave the area:

To show the driver that it is clear to leave the area, point at the driver, then point to the direction the truck is to travel.



This page intentionally left blank.

APPENDIX "A"

Sample Monthly / Annual Gin Pole Truck Inspection Form

Date:		Time:		Truck #:			
Gin Truck Owner:				Make:			
Facility Name and Location:				Vin:			
Inspector:				Year:			
#	Component(s)	SAT	UNS	N/A	CDI	Correction Date	Correction Confirmed
Truck (Outside)							
1	Clearance, Tail and Headlights in place – clean and operational						
2	Stop and Turn lights in place - clean and operational						
3	Working Lights in place - clean and operational						
4	Wiring free of damage and installed to prevent damage from moving parts						
5	Reflectors and Reflective tape in place						
6	Windshields free of damage and wipers operational						
7	Exhaust free of leaks and in good condition						
8	Fuel Tanks free of leaks and steps in good condition						
9	Cab and Hood securement in place and free of damage						
10	Mirrors in place and free of damage						
11	Back-up Alarm in place and operating						
12	Steering linkage and Gear boxes secured and free of excessive wear						
13	Front Axle Tires: Wheels and fasteners free of damage and within tread depth guidelines 4/32"						
14	Front Brake Assembly free of damage and excessive wear						
15	Front Suspension Components free of damage and excessive wear						
16	Drive Axle Tires: Wheels and Fasteners free of damage and within tread depth guidelines 2/32"						
17	Drive Axle Brake Assembly free of damage and excessive wear						
18	Drive Axle Suspension Components free of damage and excessive						
Truck (Inside)							
19	Horn in place and operational						
20	Low Air Warning device operating correctly						
21	Wiring free of damage and installed to prevent damage from moving parts						
22	Seats and Seatbelts secured and operational						
23	5 lb ABC Fire Extinguisher mounted, charged and has annual inspection						
24	Triangle Warning Reflectors in place and in good shape						
25	Current paperwork for Truck and Trailer in place and legible						
26	Current Annual DOT Inspection Sticker						
27	Truck free of excessive air leaks						
27	Fully stocked First Aid / Body Fluid Clean-up Kit available						
29	Winch Controls in working order, properly mounted and free of damage						
Truck (Bed)							
30	Bed and Winch mounts free of cracks and damage						
31	Bed free of cracks (fifth wheel and or pin, sheep's tail, headache, etc.)						
32	Gin Poles external welds and ends free of cracks and excessive wear*						
33	Lower Gin Pole pins and securement devices free of cracks and excessive wear*						
34	Sky Pin free of cracks and excessive wear*						
35	Sky Bridal / Wishbone free of cracks and excessive wear*						
36	Toggle Link(s) free of cracks and excessive wear *						
37	Tailboard Block(s) free of cracks and excessive wear Rating in tons:						
38	Sky Block(s) free of cracks and excessive wear* Rating in tons:						
39	Bottom Guy Block(s) free of cracks and excessive wear* Rating in tons:						
40	Top Guy Block(s) free of cracks and excessive wear* Rating in tons:						
41	# 1 Winch Line (active portion) free of damage Line size:						
42	# 2 Winch Line (active portion) free of damage Line size:						
43	# 3 Winch Line (active portion) free of damage Line size:						
44	Tail chain(s) free of cracks and excessive wear						
45	Winch Line Termination Device free of cracks and excessive wear						
46	All Lifting Slings and Bridles tagged and free of excessive wear						
47	Chains and Binders free of excessive wear and damage (ratchet binders only)						
48	Chart indicating the current rated load of the truck is posted on(in) the truck.						
* Annual Inspection includes all the above. In addition items 32 – 36 are to be disassembled as necessary and non-destructive testing completed and documented. NDT documentation is to be attached to this form. Items 37 – 40 should be inspected as per the manufacturer's recommended procedures.							
Inspector's Signature:				Repairman's Signature:			
Comments:							
SAT - Satisfactory Condition UNS - Unsatisfactory Condition N/A - Not Applicable CDI - Corrected During Inspection							

APPENDIX "B"

Hoisting Signals



HOIST THE LOAD



LOWER THE LOAD

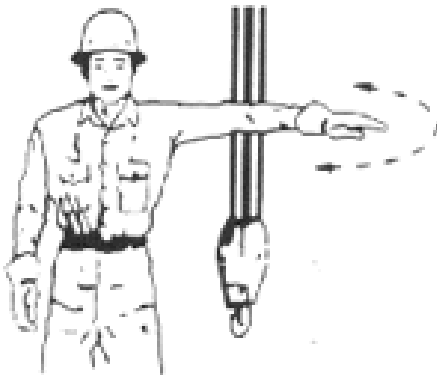

STOP

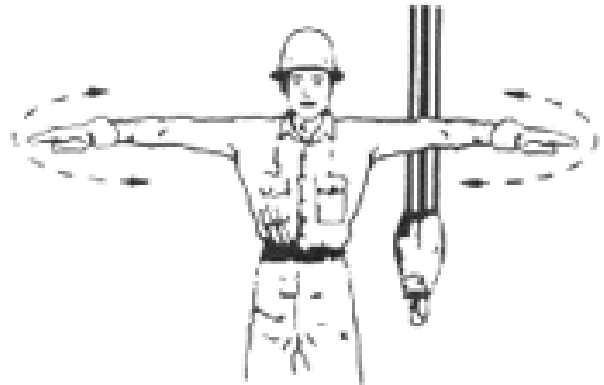

EMERGENCY STOP

APPENDIX "C"

Truck Movement Signals:



FORWARD: Palms facing away from body.

BACKWARD: Palms facing toward the body.

STOP TRUCK MOVEMENT



TURN TOWARD DRIVERS RIGHT



STOP TRUCK TURNING

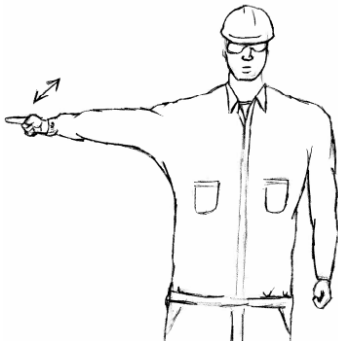

TURN TOWARDS DRIVERS LEFT

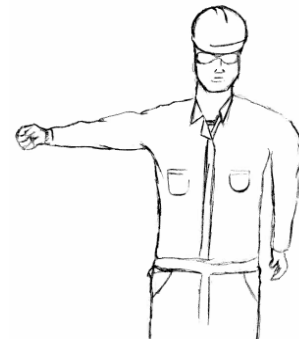

STOP TRUCK TURNING



DISTANCE TO STOPPING POINT



STOP



DRIVER TO LEAVE THE AREA

International Association of Drilling Contractors
10370 Richmond Ave. Suite 760
Houston, Texas 77423